



# LANDSCAPE RESTORATION SPECIFICATIONS

Department of Parks,  
Recreation and Open Space  
July 2020

3280 Redstone Park Circle  
Highlands Ranch, CO 80129  
303-791-2710

[highlandsranch.org](http://highlandsranch.org)



## Table of Contents

Parks and Parkways Landscape.....	3
1.01 General Notes .....	3
1.02 Site Preparation and Traffic Control .....	3
1.03 Grading, Drainage, Erosion and Sediment Control.....	4
1.04 Existing Landscape Consideration.....	4
1.05 Soil Amendment.....	4
1.06 Sod Installation .....	5
1.07 Repairing Sod Damage .....	5
1.08 Rock and Wood Mulch.....	6
1.09 Tree and Shrub Installation.....	7
1.10 Concrete Curb Replacement and Flatwork Repair.....	11
1.11 Retaining Walls .....	12
1.12 Nursery Stock Plant Quality Requirements.....	12
Parks and Parkways Irrigation.....	13
2.01 General Notes .....	13
2.02 Altering Existing Mainline .....	13
2.03 Head Replacement and Layout.....	14
2.04 Electronic Valve Replacement or Repair.....	17
2.05 Quick Coupling Valve Repair .....	17
2.06 Bubbler Nozzle for Evergreen and Deciduous Trees.....	18
2.07 Metro District Coordination.....	20
Upland Reclamation of Open Space .....	20
3.01 General Notes .....	20
3.02 Reclamation Procedure.....	20
3.03 Erosion Control Blanket .....	21

3.04 Soil Amendment..... 21

3.05 Native Seed Specification..... 21

3.06 Revegetation Terms ..... 22

Fence Repair and Replacement ..... 23

4.01 General Notes ..... 23

4.02 Wood and Composite Fence Repair and Replacement ..... 24

4.03 Fence Repair and Replacement Construction Details..... 25

## **Parks and Parkways Landscape**

### **1.01 General Notes**

- A. This document represents the minimum allowable standards. Any discrepancies with the standards included in this document must be brought to the attention of the Highlands Ranch Metro District, otherwise referred to as the Metro District, prior to construction.
- B. CONTACT: Questions concerning any of the above information should be directed to the Highlands Ranch Metro District at 303-791-2710.
- C. Site must be cleared of all debris, waste and construction equipment prior to substantial completion.
- D. The Metro District reserves the right to require submittals for all materials used prior to installation.
- E. At a minimum the contractor must be available to meet with a Metro District representative twice, for a preconstruction meeting as well as a final walk through once the work is complete.
- F. Any punch list items identified during the final walk through must be addressed within 90 days of project completion. Any applicable warranty period will not begin until all punch list items have been complete.

### **1.02 Site Preparation and Traffic Control**

- A. All work must be completed according to plan, and conflicts between this document and the landscape plans should be brought to the attention of the Metro District as soon as possible.
- B. All contractors are responsible for locating all public and private utilities prior to any site work or excavation. For more information call 811.
- C. Contractor must conform to all federal, state and local codes including permitting and traffic control planning, as applicable.
- D. Proper signage for lane or sidewalk closures must be in place, according to the approved traffic control plan, prior to any site work.
- E. All contracted workers must wear proper safety equipment at all times and follow industry standards and best management practices.
- F. Contractor must have (1) copy of the plans and at least (1) copy of any necessary permits located on site at all times.

- G. All damage caused to the irrigation or landscape, even that outside the limits of work, must be repaired by contractors and returned to its original condition. The scope of work will not be considered complete or accepted until all repairs have been made.
- H. Public safety must be maintained at all times. The entire worksite must be secure and have controlled access at all times to ensure there is no risk to public safety.

### **1.03 Grading, Drainage, Erosion and Sediment Control**

- A. Contractors must use straw wattle and/or silt fence as needed to prevent top soil run off. Rock Socks must also be in place at all storm sewer intakes prior to storm events to prevent run off from entering the storm water system.
- B. All finished slopes should not exceed 70% or 35 degrees.
- C. To achieve proper fine grade contractor must at a minimum remove all material greater than or equal to 1" in size and rake smooth.
- D. Rough and fine grade must be approved by a Metro District representative prior to adding any landscape material, including but not limited to soil, mulch, rock or sod.

### **1.04 Existing Landscape Consideration**

- A. All contractors must contact the Metro District at least 5 business days prior to commencement of any construction work. A preconstruction meeting may be required at the Metro District's discretion. This meeting would be held at the project site and attended by project manager or foreman.
- B. The Metro District Forestry Section must be informed prior to construction if the root zone of an existing tree to remain may be impacted. No existing roots on a tree to remain may be cut by any contractors without specific approval from the Metro District Forestry Section Supervisor.

### **1.05 Soil Amendment**

- A. All permeable areas must be amended with 4yds/1,000sf of amended top soil, tilled at least 6" deep. Amended top soil should consist of a 3:1 mix of Class 1 compost (EKO Compost or similar) and screened top soil.

- B. All trees and shrubs must be backfilled with 1/3 amended top soil and 2/3's native soil.
- C. Perennials beds should receive planters mix in place of amended top soil at a rate of 4 yds. per 1000 sf. Planters mix should be A1 Organics or similar.
- D. Soil amendment may need to be incorporated by hand while working in the root zone of existing plant material.
- E. Contractor must flag all irrigation heads or other obstructions prior to tilling in planters mix to avoid damage.

### **1.06 Sod Installation**

- A. Any damage to existing turf grass must be replaced with sod not seed, unless otherwise directed by a Metro District representative.
- B. Finished grade of topsoil must be 1" below the desired sod elevation.
- C. Perimeter of sod must be cut to provide an even edge. The elevation of new sod must provide a smooth transition to existing sod.
- D. The crown of turf should be level with any adjacent curb or sidewalk, if applicable.
- E. Sod type should be a Bluegrass/Fescue Hybrid whenever possible. The Metro District must approve any changes.
- F. Contractor must spade a 4" angled cut to serve as an edge between rock/wood mulch and sod. No metal edging may be used anywhere.

### **1.07 Repairing Sod Damage**

- A. When approved by the Highlands Ranch Metro District, overseeding damaged sod is a viable way to restore the landscape.
- B. Contractor shall aerate the damaged area in three passes at different angles, leaving all cores in place. When irrigation is present, aeration shall stay 6" from adjacent concrete to avoid damage.
- C. Contractor shall broadcast the approved Highlands Ranch fescue mix (see below) at a rate of 6 lbs. per 1,000 sf.

- D. Contractor shall then drag in amended top soil at a uniform depth of 1/4 " coverage, or 1 yd/1,000 sf.
- E. Contractor shall coordinate with the Metro District to make sure that the irrigation is set for establishment.
- F. Approved Seed Mix for overseeding bluegrass sod:  
"Turf Saver RTF Yellow Jacket"

RTF Rhizomatous Tall Fescue	95%
Turf Blue HGT	5%

Available at Harrell's  
 3240 Fillmore Ridge Heights  
 Colorado Springs, CO 80907  
 1-800-282-8807

**1.08 Rock and Wood Mulch**

- A. Material should match adjacent landscape beds whenever possible.
- B. Landscape fabric (Mirafi 140N or similar) with pins to be used under all rock mulch.
- C. If cobble (2-4" or larger) is used, pea gravel must be infilled to hide fabric. Refer to the landscape plan for specific size and color. If there is not a landscape plan provided cobble match existing or get approved by the Metro District prior to installation.
- D. Install a 4" thick layer of double ground shredded hardwood mulch, unless otherwise noted. Refer to the landscape plan for specific variety.
- E. Mulch along concrete should be tapered down along that edge so that the top of mulch and top of concrete are at the same elevation.
- F. Contractor must spade a 4" angled cut to serve as an edge between rock/wood mulch and sod. No metal edging may be used anywhere.

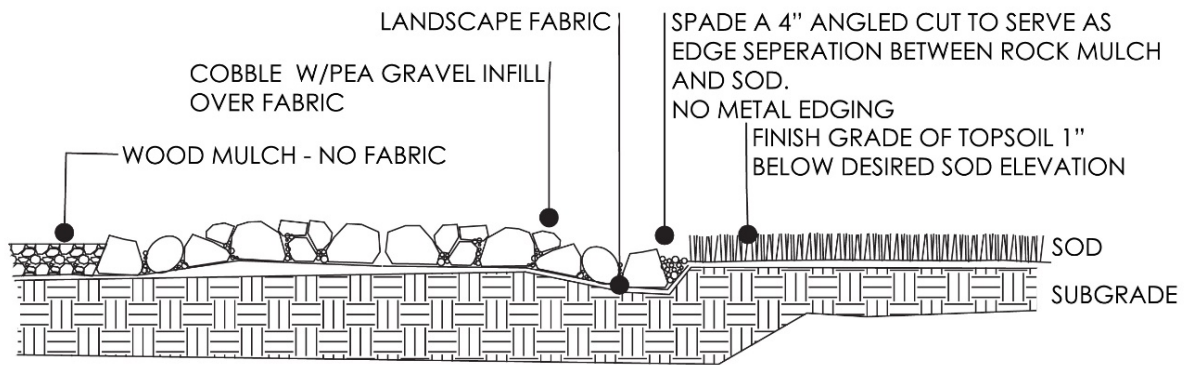

WOOD MULCH/ROCK MULCH/SOD

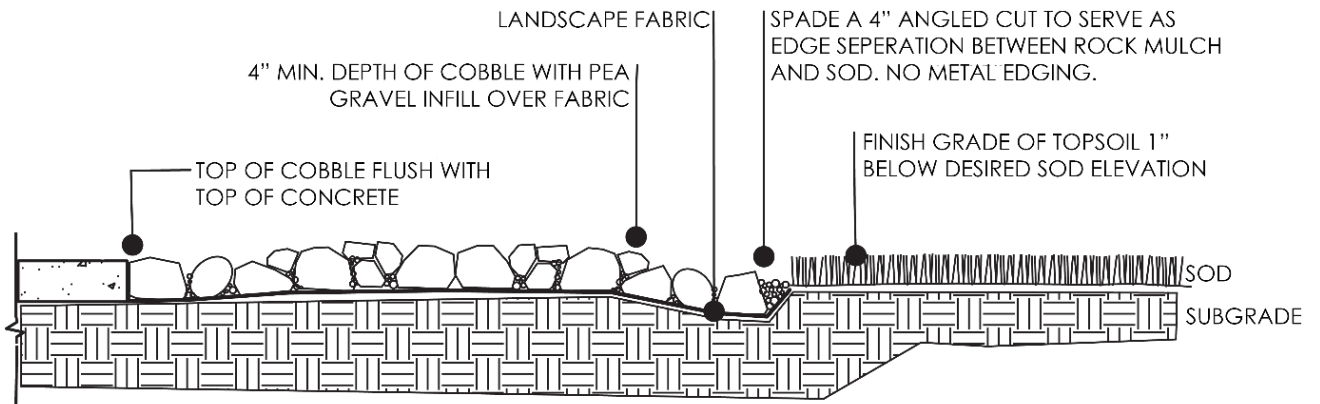

ROCK OR WOOD MULCH ALONG CONCRETE

### 1.09 Tree and Shrub Installation

- A. All contractors must follow irrigation, soil amendment and planting standards outlined in this document. See detail below.
- B. The Metro District Forestry Section reserves the right to inspect all trees and shrubs and reject any that do not meet our standards.



- C. All contractors must identify or supply an adjacent water source to be used once the planting hole is backfilled. A hose must be used to settle soil and fill in any air pockets to prevent settling.
- D. In addition to the notes listed in the installation details, contractors must also score the sides and bottom of any container plantings to ensure they do not get root bound once planted.
- E. Tree stakes to be removed one year after planting.
- F. All twine, plant ID tags, nursery tags etc. should be removed before planting.
- G. Conifers must be planted between May 15<sup>th</sup> and September 15<sup>th</sup>. Planting outside that time frame will require written approval from Metro District representative.

TREE STAKING PLAN VIEW

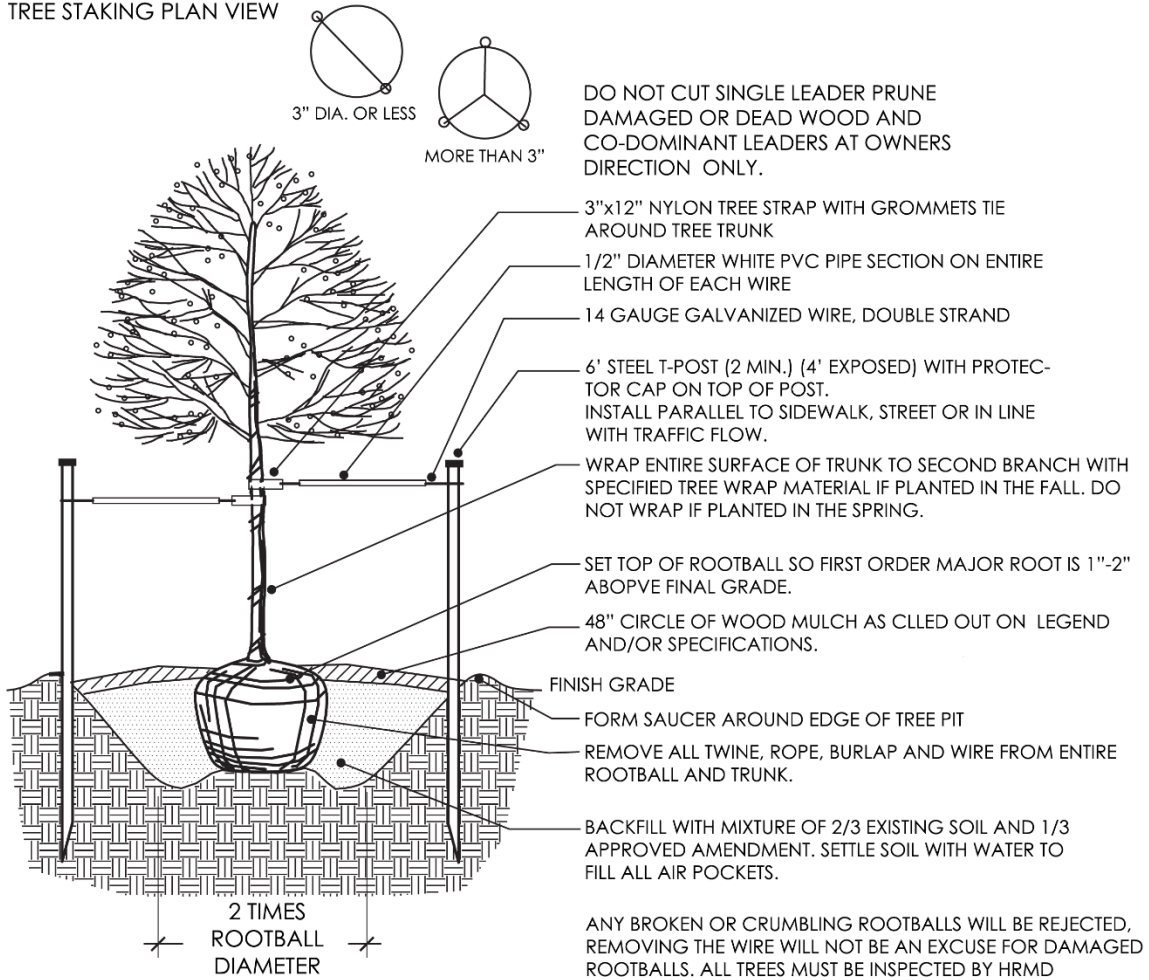

DECIDUOUS TREE PLANTING

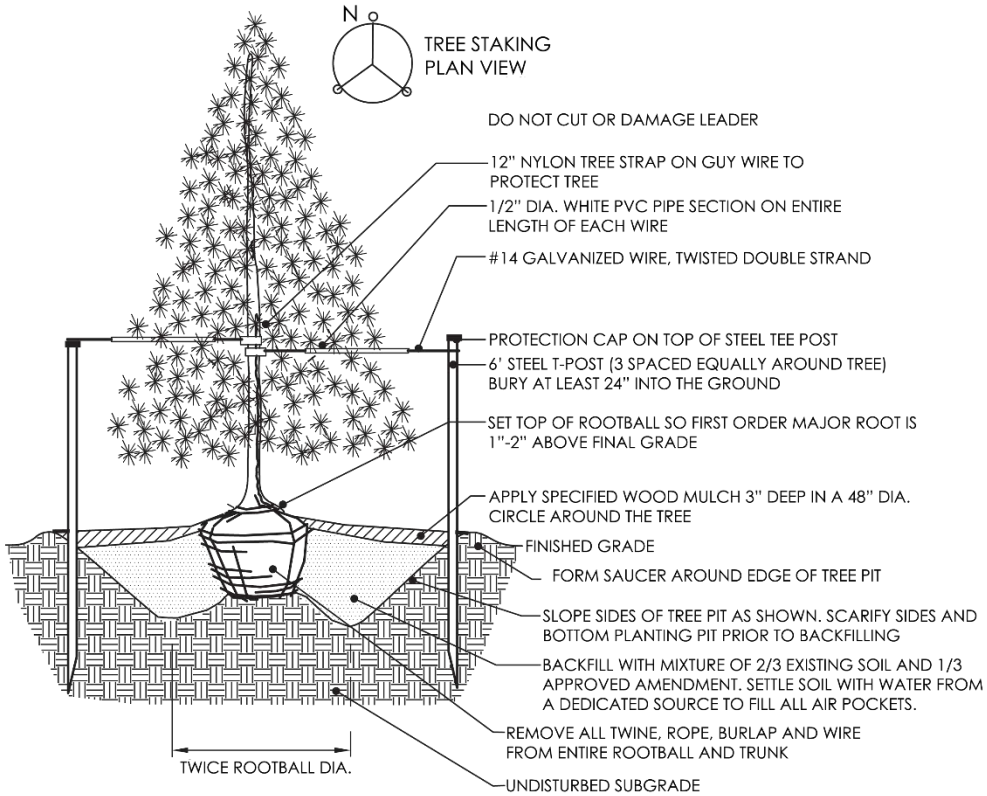

○ **EVERGREEN TREE PLANTING**

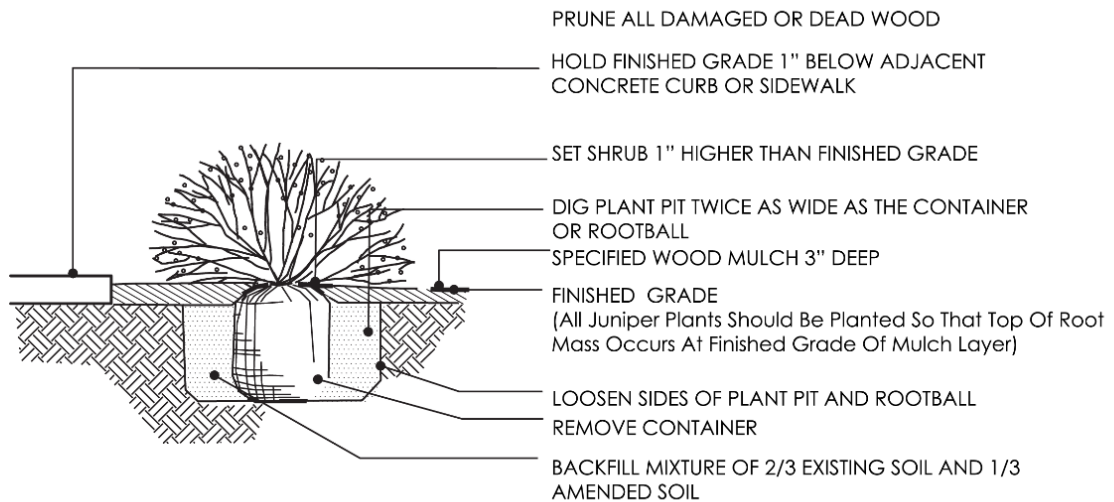

○ **SHRUB/ORNAMENTAL GRASS PLANTING**

## **1.10 Concrete Curb Replacement and Flatwork Repair**

- A. All contractors must follow best management practices for pouring and finishing concrete in Colorado. This includes all site security and safety standards.
- B. This document is for standard replacement of flatwork damaged during construction. All new or large areas of concrete or asphalt should follow the corresponding landscape plan and/or specified scope of work.
- C. Contractor must backfill all forms to meet existing grade at a reasonable slope.
- D. If working on an accessible route, all ADA guidelines must be maintained.
- E. Depth of concrete should match the adjacent slabs depth and never less than 4".
- F. All concrete should maintain a PSI of 4,000 or greater.
- G. Contractor should use #4 rebar or greater when attaching to adjacent slabs.
- H. Compaction of subgrade must be completed to eliminate settling. It is expected that any new concrete will sheet flow surface water in accordance with existing drainage patterns.
- I. When applicable, contractors should adhere to the following details:

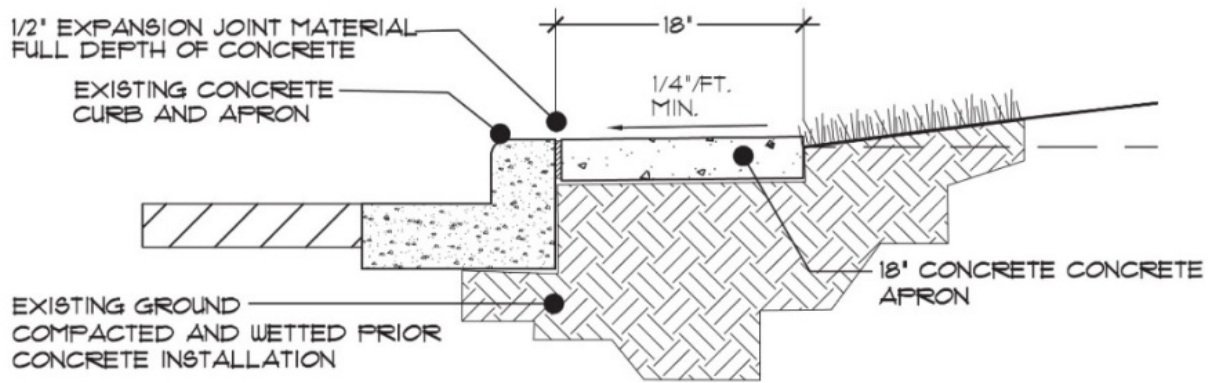

○ 18-INCH CONCRETE APRON

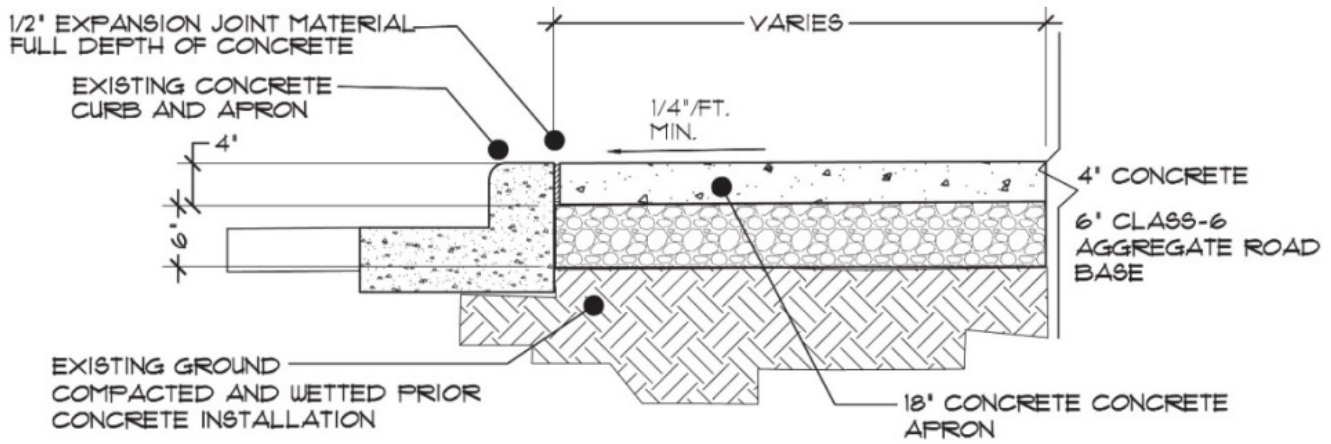

○ CONCRETE NOSES

### 1.11 Retaining Walls

- A. Contractor must coordinate with the Metro District for all retaining wall work including repair of those damaged during construction.
- B. A Douglas County building permit is required for all retaining walls over 4 feet in height, measured from the top of that wall to the bottom of the footing.  
<https://www.douglas.co.us/land/building/apply-for-permits/retaining-wall/>

### 1.12 Nursery Stock Plant Quality Requirements

- A. Contractor must follow ANSI\_Nursery Stock Standards in American Horticulture (2014) and ANSI A300 Tree Care Industry Association Standards. The Metro District can provide a copy for reference.

- B. In addition to those guidelines, plant material may be rejected by a Metro District representative if any of the following are true:
  - 1. There is any damage resulting from sunscald, frost or mechanical injury.
  - 2. There is more than 10% deadwood or any dead branches that are more than ½" in diameter.
  - 3. Plantings show signs of stress or they are not thriving.
  - 4. Limbs are excessively pruned or not pruned properly according to the ANSI standards.

## **Parks and Parkways Irrigation**

### **2.01 General Notes**

- A. This document represents the minimum allowable standards. Any discrepancies with the standards included in this document must be brought to the attention of the Highlands Ranch Metro District, otherwise referred to as the Metro District, prior to construction.
- B. CONTACT: Questions concerning any of the above information should be directed to the Highlands Ranch Metro District at 303-791-2710.
- C. Site must be cleared of all debris, waste and construction equipment prior to substantial completion.
- D. The Metro District reserves the right to require submittals for all materials used prior to installation.
- E. At a minimum the contractor must be available to meet with a Metro District representative twice, for a preconstruction meeting as well as a final walk through once the work is complete.
- F. Any punch list items identified during the final walk through must be addressed within 90 days of project completion. Any applicable warranty period will not begin until all punch list items have been complete.

### **2.02 Altering Existing Mainline**

- A. Follow all irrigation notes and details according to the landscape plan. Any conflicts should be brought to the owner's attention as soon as possible.
- B. Contractor must use class 200 pipe unless otherwise specified.

- C. Irrigation wires to be placed below and to the side of mainline.
- D. There should be enough additional wire to lift three feet above grade once restored.
- E. All splices should be performed with Direct Burial wire splices:
  1. The DBY and DBY-6 splice kit connects a wire range of 2-5 #18 AWG through 2 #12 plus 1 #16 AWG solid or stranded copper wire.
  2. The DBR and DBR-6 splice kit connects a wire range of 5 #16 AWG through 3 #10 AWG solid or stranded copper wire.
- F. All wires should be coiled into a round 10" valve box or if more than 25 splices a standard rectangular valve box should be used,
- G. All irrigation wire shall be consistent with the color of the existing wire and should be 14 AWG solid PE (UL) direct burial.
- H. Mainline should only be routed around object with 45° couplers and buried to a minimum depth of 24" below finished grade.
- I. Primer and cement must be applied to both pipe and coupler. Insert fully and rotate ¼ turn for best bonding of pipe and fittings. Wipe all excess from cemented assembly.
- J. All cemented irrigation must be set for 24 hours before water charging.
- K. All irrigation work must be approved upon inspection by a Metro District representative before it is backfilled.
- L. No glue or cement work to be completed in temperatures below 40° Fahrenheit.

### **2.03 Head Replacement and Layout**

- A. If no irrigation plan is provided contractor must consult with a Metro District representative to create a custom irrigation plan. The result of any new adjustments must provide head to head coverage.
- B. New heads and nozzles must match existing.
- C. All heads must be located 3" from the edge of sidewalk or curb to prevent damage from plows and landscape maintenance.

- D. Irrigation layout must be inspected and approved by a Metro District representative prior to installation of new plantings or sod.
- E. Lateral lines should be buried a minimum of 18" below grade.

**Pop Up Spray Head**

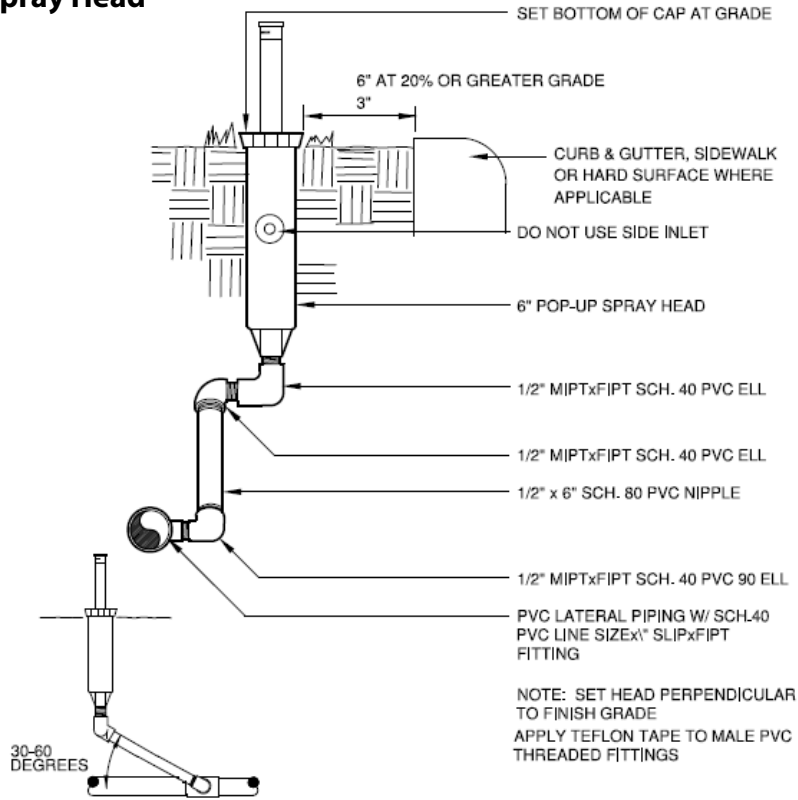



## Rotor Spray Head

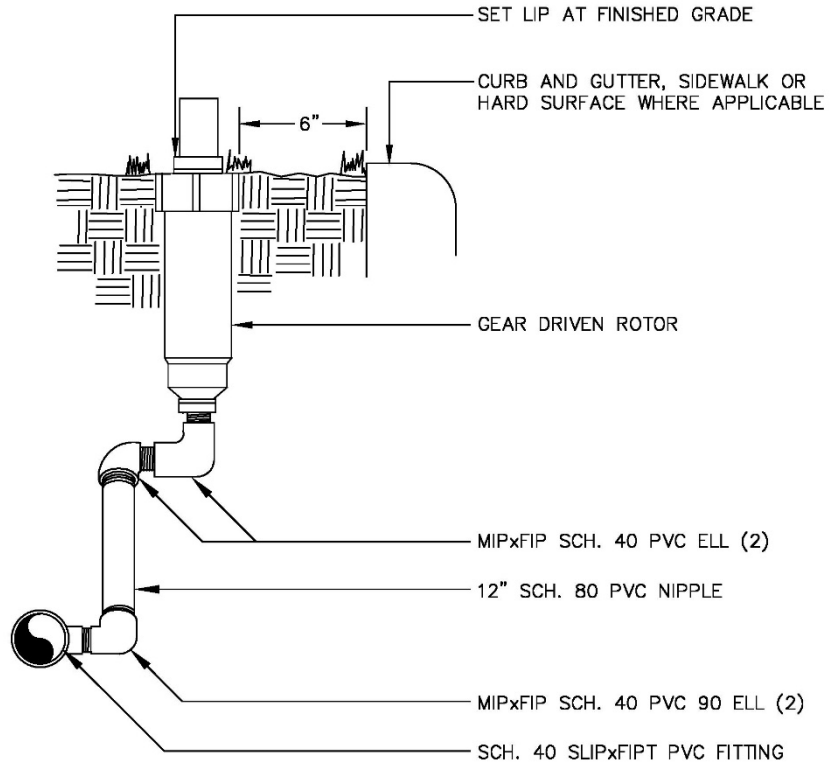

NOTE: DIAMETERS OF FITTINGS AND NIPPLES SHALL EQUAL ROTOR INLET DIAMETER

SET ROTOR PERPENDICULAR TO FINISH GRADE

APPLY TEFLON TAPE TO ALL MALE THREADED FITTINGS AND THREADED NIPPLES

MAINLINE DEPTH 24" (TYP.)

SET SWING PIPE ANGLE BETWEEN 30-60 DEGREES

## 2.04 Electronic Valve Replacement or Repair

- A. Contractor must maintain four to six inches of clearance from the valve components to the bottom of the valve box.
- B. The valve box should be set so that it does not come in contact with any of the irrigation components.

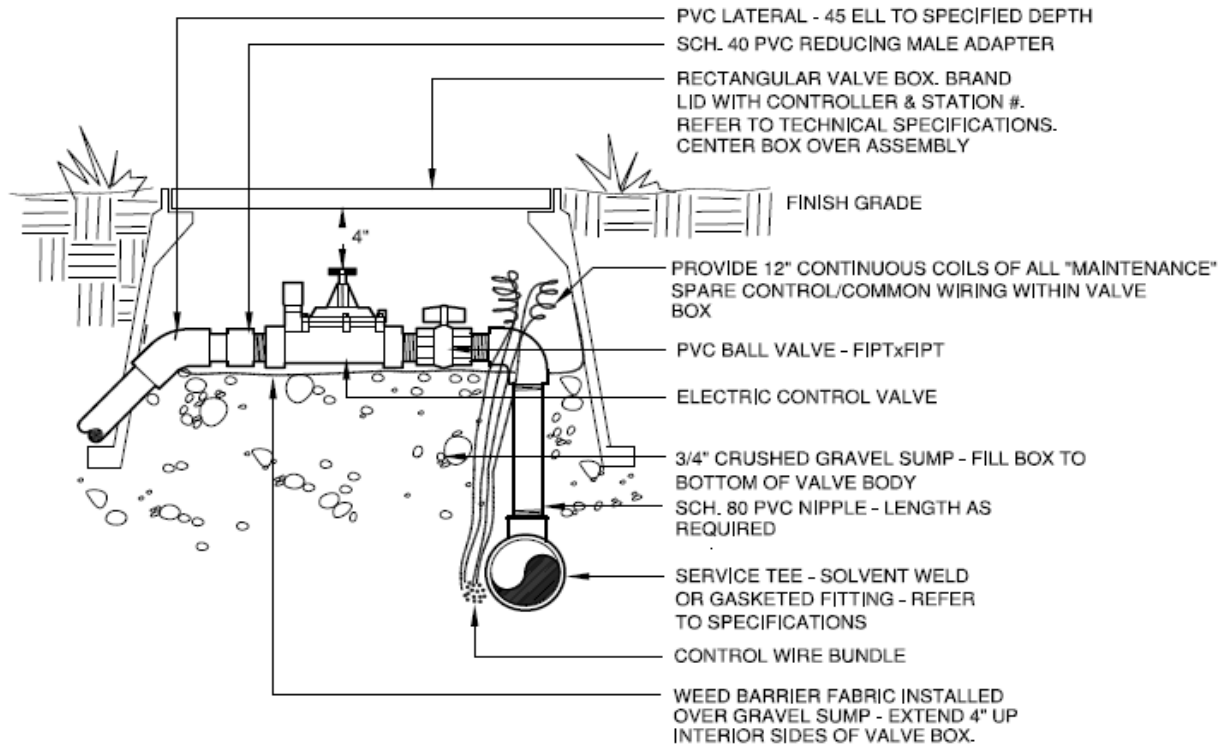

NOTE: DIAMETERS OF BALL VALVES, PVC FITTINGS AND NIPPLES SHALL EQUAL ELECTRIC CONTROL VALVE DIAMETER  
VALVE BOXES SHALL BE INSTALLED PARALLEL OR PERPENDICULAR TO ADJACENT SIDEWALKS AND HARD SURFACES WHERE APPLICABLE  
APPLY TEFLON TAPE TO ALL MALE THREADED FITTINGS AND THREADED NIPPLES  
MAINLINE DEPTH 24" (TYPICAL)

## 2.05 Quick Coupling Valve Repair

- A. Quick coupler repair must also include the swing arm.
- B. Contractor must leave at least 4" of clearance from the top of the coupler valve to the bottom of the 10" round valve box. (See detail below.)

- C. Large repairs and/or major changes to the system may require as-built drawings or other documentation.

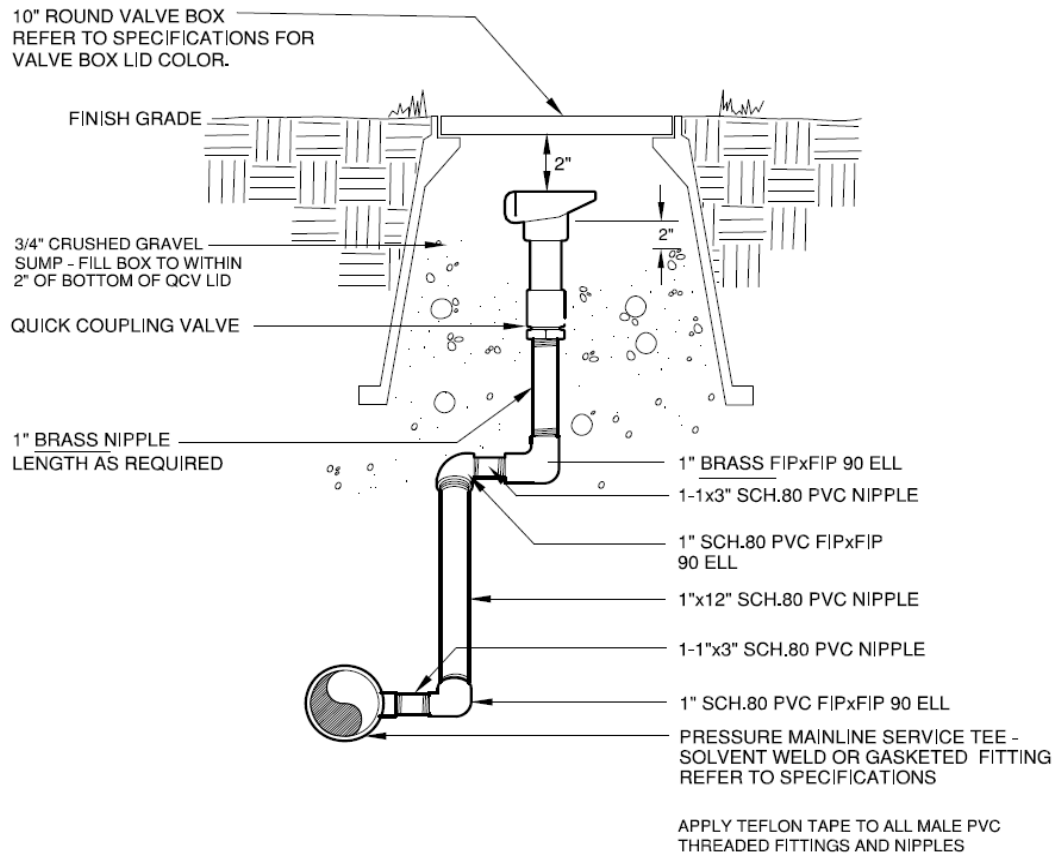

## 2.06 Bubblers for Evergreen and Deciduous Trees

- A. Contractor shall install two bubblers on opposing sides of each tree, new and existing, on the uphill side if applicable.
- B. Bubblers shall be Rainbird 1402
  - a. Product ID: A16120, Model ID: 1402
  - b. <https://www.rainbird.com/products/1400-series-pressure-compensating-bubbler>
  - c. Contractor shall ensure that staking of new trees does not interfere with location of bubblers.
- C. Please see diagram below for approximate locations of bubblers. Any questions about placement or installation should be brought to the attention of the owner and handled before any work is complete.

## Bubbler Nozzle Layout

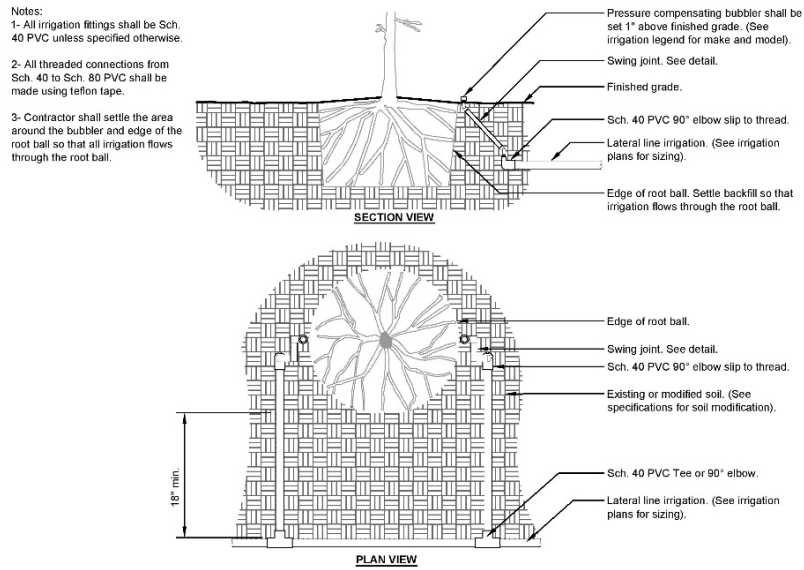

(I-X) IRRIGATION BUBBLER (2) W/ LAYOUT

URBAN TREE FOUNDATION © 2014  
OPEN SOURCE FREE TO USE

## Bubbler Nozzle Detail

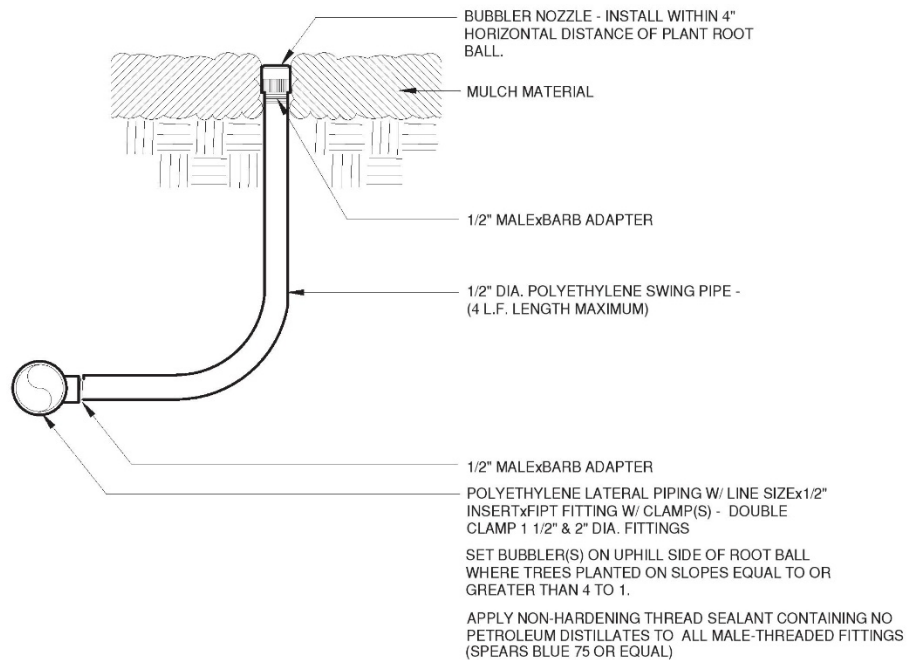

## **2.07 Metro District Coordination**

- A. All irrigation work must be approved by a Metro District representative before anything is backfilled. New installations must be approved prior to installation.
- B. Contractor must contact the Metro District at least 48 hours in advance of installing any sod or plantings.
- C. No sod may be laid on a Friday or before any Metro District holiday.
- D. Metro District reserves the right to reject any work that was not done according to these standards and any landscape or irrigation plans provided to the contractor.
- E. Discrepancies between plans must be brought to the attention of the Metro District, who will direct the contractor how to proceed.

## **Upland Reclamation of Open Space**

### **3.01 General Notes**

- D. Contractor must follow all standards included in Parks and Parkways Landscape including sections 1.01-1.04, 1.07 and 1.08. These sections cover Site Prep, Traffic Control, Grading, Drainage, Erosion and Sediment Control, Existing Landscape Consideration, Soil Amendment, Tree and Shrub Installation as well as Concrete Curb and Flatwork.

### **3.02 Reclamation Procedure**

- A. Contractor must use native seed mix as specified in the table below.
- B. For slopes at or greater than 3:1, seeding by hand or broadcast spreader may be done with the approval from the Metro District, broadcast seeding rates must be double that of the drill seeding rates.
- C. Seed must be planted with a drill that is specifically designed to accommodate the variety of sizes and physical characteristics of the native rangeland grass seeds specified below.
- D. Drill depth bands should be placed ¼" to ½" below grade and spaced no greater than seven inches apart.
- E. Contractor must use packer wheels to ensure soil to seed contact.

- F. Once seed has been drilled in, contractor must apply straw mulch throughout the site and then crimp it into the soil so that it remains in place. Crimping (at a minimum 2 to 3 inch depth) should take place with a rate of 3,000 lbs. of straw per acre using certified weed free straw.

### **3.03 Erosion Control Blanket**

- A. Erosion control blankets must be used on all slopes greater than or equal to a 3:1 ratio, once seed and straw is installed.
- B. Contractor must use a double net straw blanket, made from woven jute netting and is 100% biodegradable (i.e. S150 BN).
- C. A minimum overlap of four inches is required between rolls.
- D. Top slope edge of blanket must be staked 4-6 inches deep and backfilled.
- E. Stakes will be spaced 2-3 feet apart and anchored along the edge and center of the blanket.

### **3.04 Soil Amendment**

- A. All permeable areas must be amended with 3yds/1,000sf of amended top soil, tilled at least 6" deep. Amended top soil should consist of a 3:1 mix of Class 1 compost (EKO Compost or similar) and screened top soil.
- B. Soil amendment may need to be incorporated by hand while working in the root zone of existing plant material.
- C. Contractor must flag all irrigation heads or other obstructions prior to tilling in planters mix to avoid damage.

### **3.05 Native Seed Specification**

- A. All contractors must use the Dry/Upland specified below. Drill seed rates of 33.5 lbs. of pure live seed (PLS) per acre. Purity and germination tests for all seed should be less than one year old.

<b>Species</b>	<b>Variety</b>	<b>% of Mix</b>	<b>Rates (PLS)</b>
Western Wheatgrass	Arriba	12	4.0
Thick Spick Wheatgrass	Critana	18	6.0
Sideoats Grama	Native	12	4.0
Blue Grama	Native	25	8.5
Little Bluestem	Native	16	5.4
Prairie Sandreed	Goshen	12	4.0
Sand Dropseed	Native	5	1.6
<b>Total</b>		<b>100</b>	<b>33.5 lbs</b>

B. Any substitutions must be approved by a Metro District representative prior to installation.

C. Highlands Ranch Metro District Seed Mix available at:

Granite Seed Company - 490 East 76<sup>th</sup> Ave. Unit A Denver, CO 80229

Phone: 720-496-0600

Arkansas Valley Seed Company - 4300 Monaco Street Denver, CO 80216

Phone: 303-320-7500

D. Contractor must supply seed tag at time of installation to verify the correct seed mix is being used.

<b>Species</b>	<b>Variety</b>	<b>Site Type</b>	<b>Season</b>
Sand Bluestem	Garden	Wet	Warm
Prairie Junegrass	None	Wet	Cool
Canada Wildrye	None	Wet	Cool

### **3.06 Revegetation Terms**

A. Seeding rates are specified in terms of "pounds of pure live seed (PLS) per acre or unit area. In a mix, each species contributes to the mix, expressed as a

percent of the rate for a pure stand of that specific species. The number of seeds per pound varies by species, so percentages by weight are misleading.

## **Fence Repair and Replacement**

### **4.01 General Notes**

- A. All contractors must adhere to section 1.01 of this document.
- B. Any damage to Highlands Ranch Metro District fence must be reported to the Facilities Section at 303-791-2710, and all repair work must be completed as soon as possible.
- C. Throughout ongoing repair work, the fence perimeter must be maintained with a temporary fence at least 4' in height, made of chain-link or similar construction fence. This is so that the site remains secure during construction.
- D. The intention of all repair work is that the fence is brought back to its original condition or improved upon.
- E. Contractors must coordinate with the Metro District to inspect and approve all modifications before the work can be considered complete.
- F. This document is meant for repairs of existing fence, to be done by professional contractors only. All residents must follow the Highlands Ranch Community Association (HRCA) Residential Improvement Guidelines (RIGs), available on their website: [hrcaonline.org](http://hrcaonline.org).
- G. Any repair to composite fence must also comply with the Metro District's most current "Specifications for fence replacement".
- H. All contractors must follow the construction details below, as applicable to the type of fence repair being completed. If the existing fence differs from the details below, contractor must match the existing adjacent fence.



#### **4.02 Wood and Composite Fence Repair and Replacement**

- A. All contractors must follow the construction details below, as applicable to the type of fence repair being completed. Contractor must match the existing adjacent fence whenever possible, even if that differs from the details below.
- B. Both wood and composite privacy fence should utilize the same EZ Mason columns.
- C. Gates are prohibited and may not be added to any existing fence. If there is an existing gate for Metro District maintenance purposes, that gate should remain and be repaired as needed.
- D. Composite fence should be Trex Seclusions, in Saddle with a flat cap.
- E. For more information on the composite fencing, or the complete installation guide please visit [trexfencing.com](http://trexfencing.com).

## 4.03 Fence Repair and Replacement Construction Details

### F.1 CEDAR PRIVACY FENCE

#### 6' PRIVACY FENCE FRONT ELEVATION

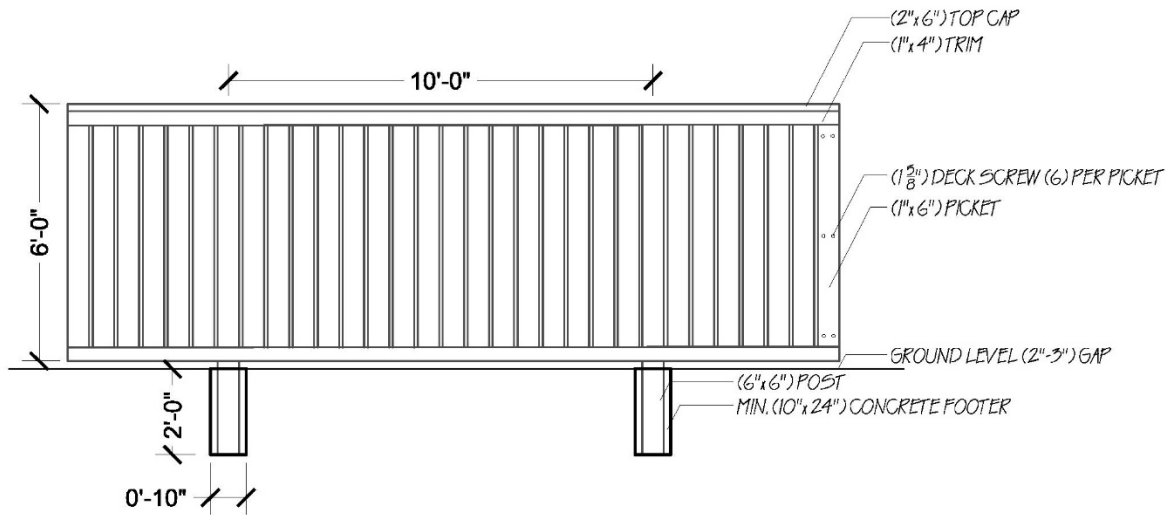

#### CONSTRUCTION NOTES:

ALL WOOD MUST BE ROUGH SEWN CEDAR  
MAY SUBSTITUTE DECK SCREWS FOR HOT DIPPED GALVANIZED RING SHANK NAILS.  
ALL CONTRACTORS ARE RESPONSIBLE FOR LOCATING ALL PUBLIC AND PRIVATE UTILITIES.  
HRMD MUST BE NOTIFIED IMMEDIATELY OF ANY IRRIGATION DAMAGE.

# 6' PRVACY FENCE REAR ELEVATION

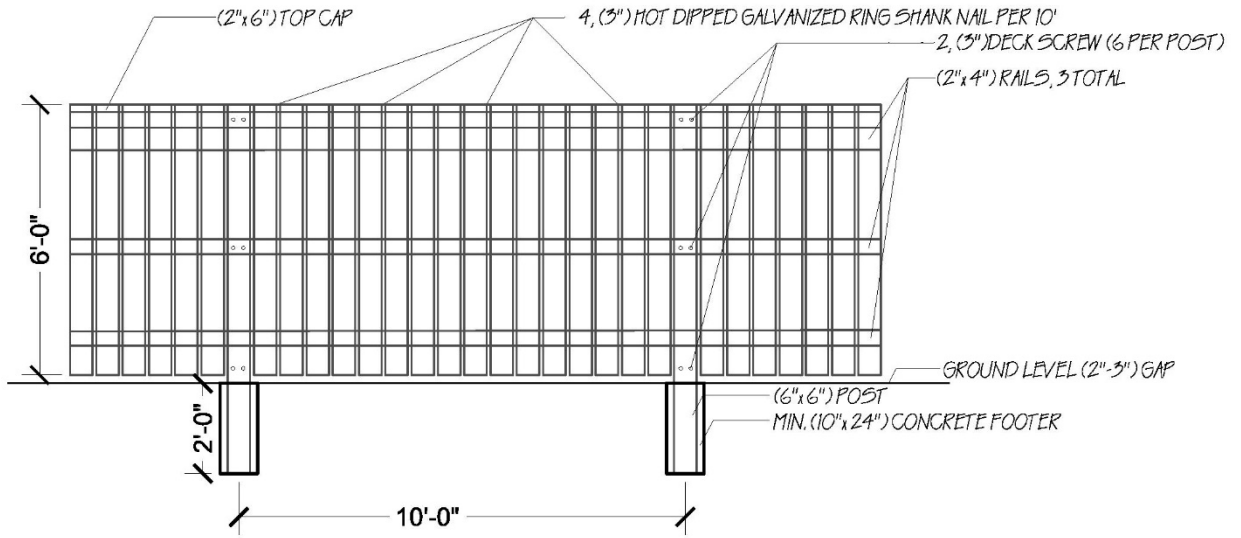

# 6' PRNACY FENCE SIDE ELEVATION

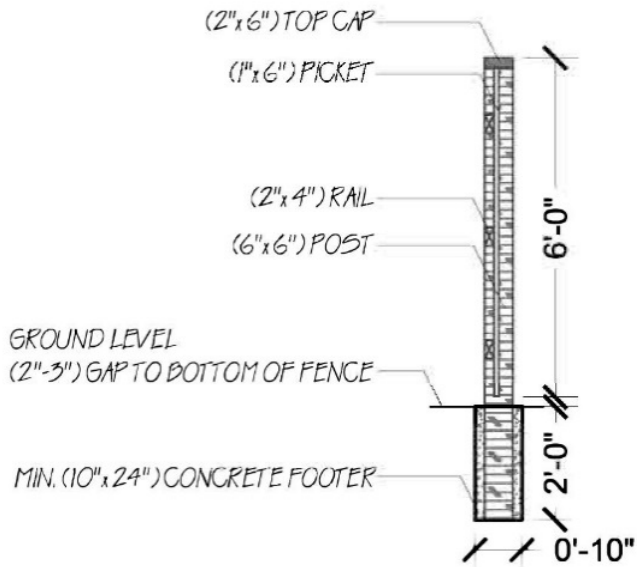

CONSTRUCTION NOTES:  
PLEASE NOTE ALL RAILS AND PICKETS ARE WITHIN THE  
FRAME OF THE (6"x6") POSTS.

**F.2 PREFABRICATED POLY COLUMN**

*PREFABRICATED COLUMN  
FRONT ELEVATION*

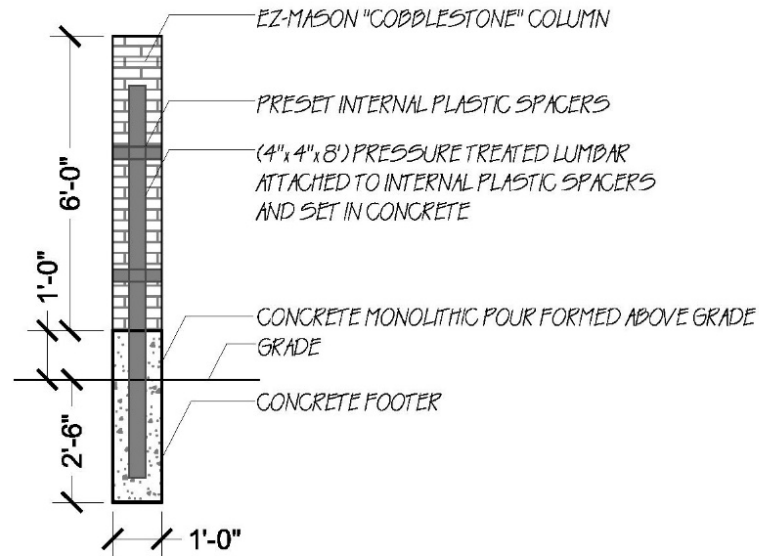

*CONSTRUCTION NOTES:  
NU-WOOD PREFABRICATED POLY COLUMN 574-457-2062, MUST MATCH EXISTING.  
COLUMNS SHOULD ONLY BE REPLACED IN THE EXACT LOCATION OF THE EXISTING COLUMN.  
ALL CONTRACTORS ARE RESPONSIBLE FOR LOCATING ALL PUBLIC AND PRIVATE UTILITIES.  
HRMD MUST BE NOTIFIED IMMEDIATELY OF ANY IRRIGATION DAMAGE.*

**F.3 TWO RAIL OPEN FENCE: REPAIR DETAILS**

2 RAIL FENCE  
FRONT ELEVATION

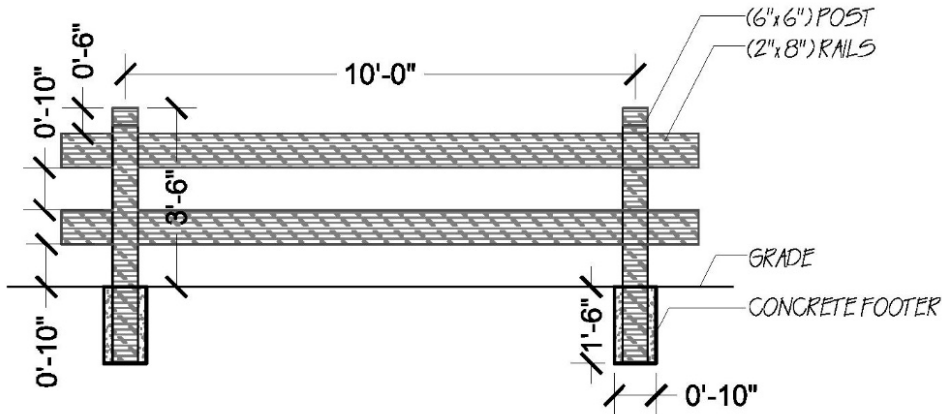

CONSTRUCTION NOTES:  
 ALL WOOD MUST BE ROUGH SEWN CEDAR  
 ALL CONTRACTORS ARE RESPONSIBLE FOR LOCATING ALL PUBLIC AND PRIVATE UTILITIES.  
 HRMD MUST BE NOTIFIED IMMEDIATELY OF ANY IRRIGATION DAMAGE.

2 RAIL FENCE  
SIDE ELEVATION

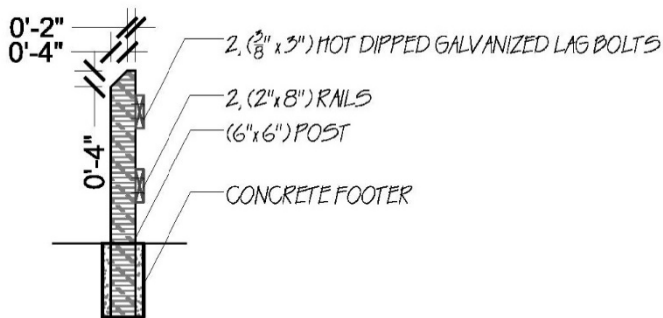

#### F4. COMPOSITE PRIVACY FENCE: REPAIR DETAILS

